

*An Online CPD Course
brought to you by
CEDengineering.ca*

Steam Distribution Systems

Course No: D02-008

Credit: 2 PDH

Elie Tawil, P.E., LEED AP



Continuing Education and Development, Inc.

P: (877) 322-5800

info@cedengineering.ca

This course was adapted from the Naval Education and Training Materials, Publication No. NAVEDTRA 14265A, “Utilitiesman Basic”, which is in the public domain.

Chapter 10

Steam Distribution Systems

Topics

- 1.0.0 Exterior Steam Distribution Systems
- 2.0.0 Interior Steam Distribution Systems
- 3.0.0 Steam Distribution System Components

Overview

As a UT you may have questions about delivering steam from the steam plant to the user. You will find information in this chapter that answer questions about steam distribution systems. A steam boiler is virtually useless for heating without a good distribution system for taking the steam to the areas to be heated.

The term distribution system, as used in this chapter, refers to the network of piping required to distribute steam from a boiler room or a boiler plant through the steam pipes to the equipment using it. In this chapter, both exterior and interior steam distribution systems are discussed, including their maintenance requirements, various components and purposes in the distribution system.

Objectives

When you have completed this chapter, you will be able to do the following:

1. Describe the different types of exterior steam distribution systems.
2. Describe the different types of interior steam distribution systems.
3. Describe the components of a steam distribution system.

Prerequisites

None

1.0.0 EXTERIOR STEAM DISTRIBUTION SYSTEMS

The exterior distribution system is divided into underground and aboveground systems. The following topics discuss these two systems in detail.

1.1.0 Underground Systems

The major underground systems are the conduit and the *utilidor* types of systems. These systems are normally installed only in permanent heating installations because of their high cost of installation.

1.1.1 Conduit Type

In the conduit type of steam distribution system, the pipe is installed inside a conduit that is usually buried in the ground below the frost line. The frost line is the lowest depth that the ground freezes during the coldest part of the winter. The pipe commonly used for steam is black steel pipe, which is not as strong as that required for condensate return lines. The conduit and insulation serve to protect and insulate the steam pipe. One type of conduit is shown in *Figure 10-1*. The conduit must be strong enough to withstand the pressure of the earth and the usual additional loads imposed upon it.

Several types of materials and various designs are used in the manufacture of conduit. Common types of conduit are constructed of masonry cement, galvanized iron, and steel. The conduit is usually sealed with asphaltic tar or some other type of sealer to prevent water from getting into the insulation and deteriorating it. Insulation may be attached directly to the pipe, attached to the inner surface of the conduit, or in loose form and packed between the pipe and the conduit.

The bottom of the trench for the conduit should be filled with coarse gravel or broken rock to provide support and adequate water drainage. When water is allowed to collect, it seeps into the conduit through porous openings in the sealer. This wets the

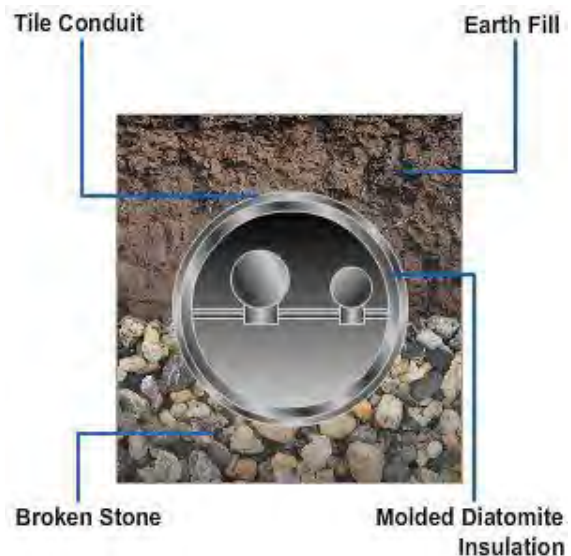

Figure 10-1 – One type of steam distribution conduit.

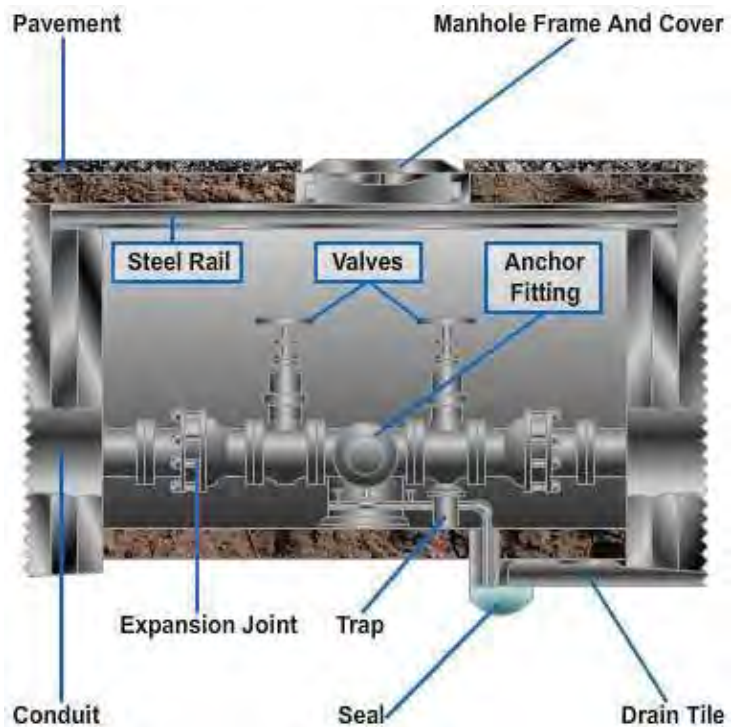

Figure 10-2 – Typical manhole for distribution system.

insulation and causes it to lose much of its insulating value.

Manholes are required at intervals along the line to give access to the necessary valves, traps, and expansion joints. A typical manhole is shown in *Figure 10-2*.

1.1.2 Utilidor Type

The utilidors, or tunnels, of the utilidor type of system are constructed of brick or concrete. The size and shape of the utilidor usually depend upon the number of distribution pipes to be accommodated and the depth the utilidor must go into the ground. Manholes, sometimes doors, are installed to provide access to the utilidor. A typical utilidor is shown in *Figure 10-3*. The utilidor is usually constructed so the steam and condensate return lines can be laid along one side of the tunnel on pipe hangers or anchors. This is usually done with the type of hanger with rollers that provides for free movement required by the expansion of the pipe. The other side of the utilidor should be a walkway that provides easy access to lines when you are inspecting and doing maintenance.

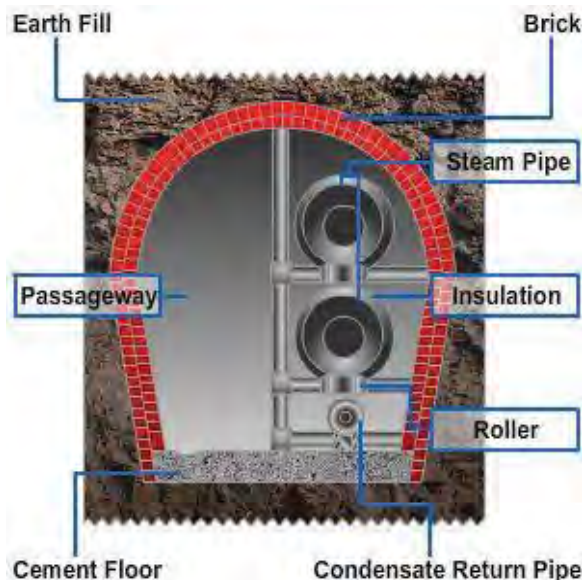

Figure 10-3 – Typical utilidor.

1.2.0 Aboveground Systems

Aboveground steam distribution systems are further divided into overhead and surface systems:

1.2.1 Overhead Distribution Systems

Overhead distribution systems are often used in temporary installations and sometimes in permanent installations. The main drawback to this type of distribution system is the high cost of maintaining it. These overhead systems are similar in many respects to underground distribution systems. They require valves, traps, provision for pipe expansion, and insulated pipes. The main difference is that the steam distribution and condensate return piping are supported on pipe hangers from poles instead of being buried underground (*Figure 10-4*).

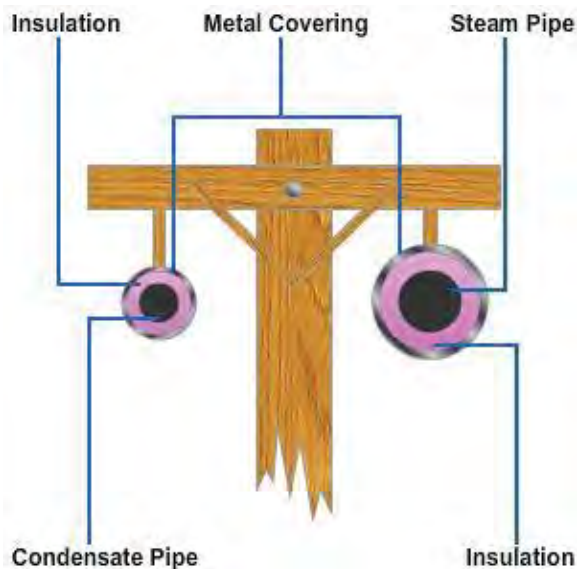

Figure 10-4 – Steam and condensate lines supported by poles.

1.2.2 Surface Distribution Systems

In some cases, you will find that steam and condensate lines are laid in a conduit along the surface of the ground. These systems, however, are not as common as overhead and underground systems. Surface systems require about the same components as the

overhead and the underground systems-traps, valves, pipe hangers to hold the pipes in place, and provision for pipe expansion. Sometimes an expansion loop, formed by a loop of pipe, is used instead of an expansion joint to provide for pipe expansion.

1.2.3 Maintenance

The maintenance required for exterior distribution systems normally consists of inspecting, repairing, and replacing insulation, traps, valves, pipe hangers, expansion joints, conduit, utilidors, and aluminum or distribution systems. The maintenance required on conduit and utilidors consists of keeping the materials of which they are constructed from being damaged and of ensuring that water is kept out of the tunnels and pipes. The maintenance required on outside metal coverings is about the same as that for the conduit and utilidors.

2.0.0 INTERIOR STEAM DISTRIBUTION SYSTEMS

Interior steam distribution systems may be classified according to pipe arrangement, accessories used, method of returning condensate to the boiler, method of expelling air from the system, or the type of control used. The interior steam systems discussed in this section are classified by pipe arrangement; they include but are not limited to: Gravity, One-Pipe, and Air-Vent System.

Steam may be fed to interior steam distribution systems from a boiler in the same building or from the exterior distribution system of a central plant.

2.1.0 Gravity, One-Pipe, Air-Vent System

The gravity, one-pipe, air-vent system is one of the oldest types of internal distribution systems (*Figure 10-5*). Its capacity is usually ample, and its installation cost is low. Because the condensate is returned to the boiler by gravity, this system is usually confined to one building and is seldom used as a central plant distribution system. The steam is supplied by the boiler and is carried by a single system of piping to the radiators. The return of condensate depends upon the hydrostatic head. Therefore, the end of the steam main, where the main is drained to the wet return, should be high enough above the waterline to provide the required hydrostatic head above the entrance to the boiler. The radiators in the system are equipped with an inlet valve and an air valve. The inlet valve is the radiator shutoff valve, while the air valve permits the venting of air from the radiators. Condensate is drained from the radiators through the same pipe that supplies the steam; they flow in opposite directions, however, which is a disadvantage. Under certain conditions, the condensate is held in the radiators. This causes noisy operation and a fluctuating water level in the boiler. Water hammer and slow heating are characteristic of this system when the pipe sizing, pitch, and general design are inadequate.

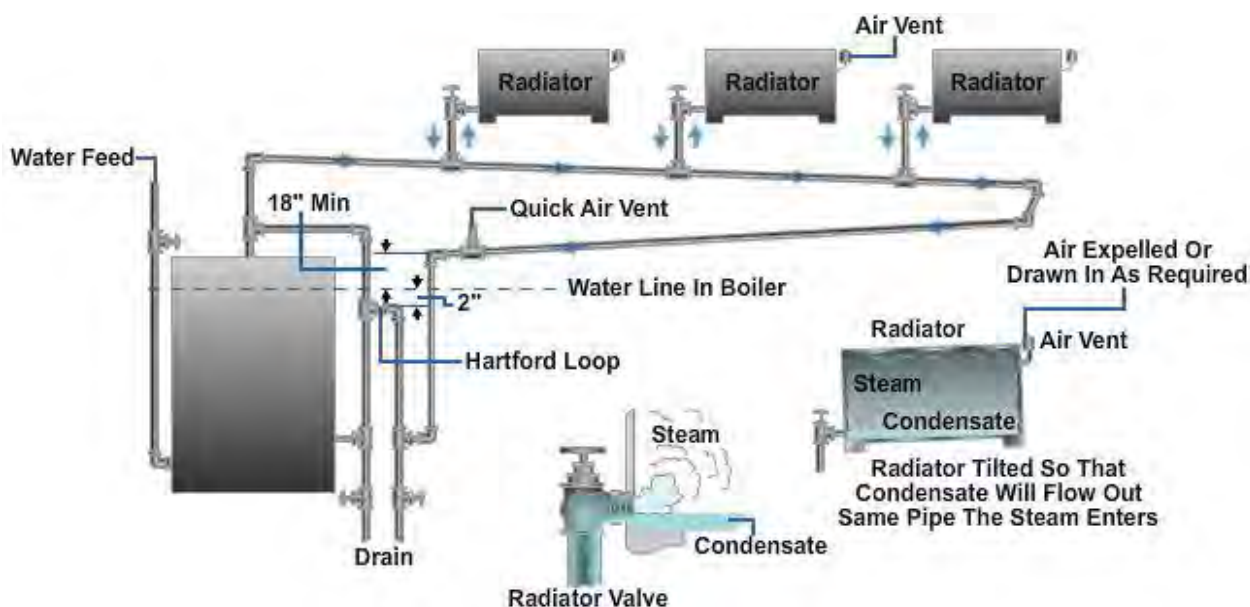

Figure 10-5 – Gravity, one-pipe, air-vent system.

2.1.1 Installation

Although all gravity, one-pipe, air-vent systems are alike in design, two installations are seldom alike in detail. Since the details differ with the make and model of equipment, the manufacturer's installation procedures should be followed. Also, you should follow the mechanical blueprints for a particular installation. There is some general information in this section that applies to most heating systems of this type.

To prevent water hammer and re-evaporation of the water, drain all condensate from the lines. The necessary internal drainage can be obtained by sloping the lines down in the direction of condensate flow, at least one-fourth of an inch for every 10 feet of pipe. The radiators must also be tilted so the condensate flows out of them into the same pipe through which the steam is entering.

Air vents are installed in the steam lines and radiators to eliminate air in the system. Air in the system tends to block the flow of steam, and it consequently acts as an insulator by preventing the emission of heat from the heating surface. Therefore, the air must be quickly and effectively vented from the heating equipment and steam lines to get quick and even heating from the steam-heating system. Most steam distribution systems are now fitted with automatic vents that permit the air to pass but which block the passage of steam. *Figure 10-5* shows air vents in the radiator and the distribution system.

2.1.2 Operation

The operating instructions for gravity, one-pipe, air-vent systems vary from one installation to another. The manufacturer of the equipment usually furnishes the specific operating instructions for the equipment.

Generally speaking, most steam systems have a main steam stop valve located on the top of the boiler. The purpose of this valve is to hold the steam in the boiler until you are ready to let it out. When you are ready to turn the steam into the distribution system, you should only crack (open very little) the valve. The reason for doing this is to allow the system to warm up slowly and avoid any thermal shock to the lines and fittings. After

the system has warmed up, open the main steam stop valve slowly. While opening the valve, check often to ensure that the proper water level is maintained in the boiler.

You will also note that the radiator valves in one-pipe steam distribution systems should be either completely open or completely closed. Partial opening of the valve interferes with the proper drainage of water from the radiator.

2.1.3 Maintenance

This section covers the problems you are most likely to encounter in the field when maintaining a gravity, one-pipe distribution system. The most probable causes of these problems and the remedies for them are also addressed.

When a radiator fails to heat or water hammer occurs, there are several probable causes. One is the failure of the air vents to function, thereby causing the radiator to become air bound. A second cause is that the radiator valves are not completely open. Another cause is that the radiators and lines are not correctly pitched. To remedy these causes of heat failure, inspect the operation of the air vents and the positions of the radiator valves to make sure they are open. Then check and correct, if necessary, the pitch of the radiators and lines when the other checks do not correct the trouble.

A fluctuating waterline in the boiler can be caused by an excessive pressure drop in the supply lines, which in turn is usually caused by partial stoppage in the pipes. This, of course, can be remedied only by removing the cause of the stoppage. Uneven heat distribution is another trouble that you may encounter. This can be caused by inoperative radiator vents, improperly vented steam mains, or incorrectly pitched mains. To eliminate this uneven heat distribution, check and clean the air vents at the radiator and those in the steam mains. Then check and correct, as required, the pitch of the steam lines if the other remedies have not corrected the trouble.

2.2.0 Two-Pipe Vapor System with a Return Trap

The two-pipe vapor system with an alternating return trap is an improvement over the one-pipe system (*Figure 10-6*).

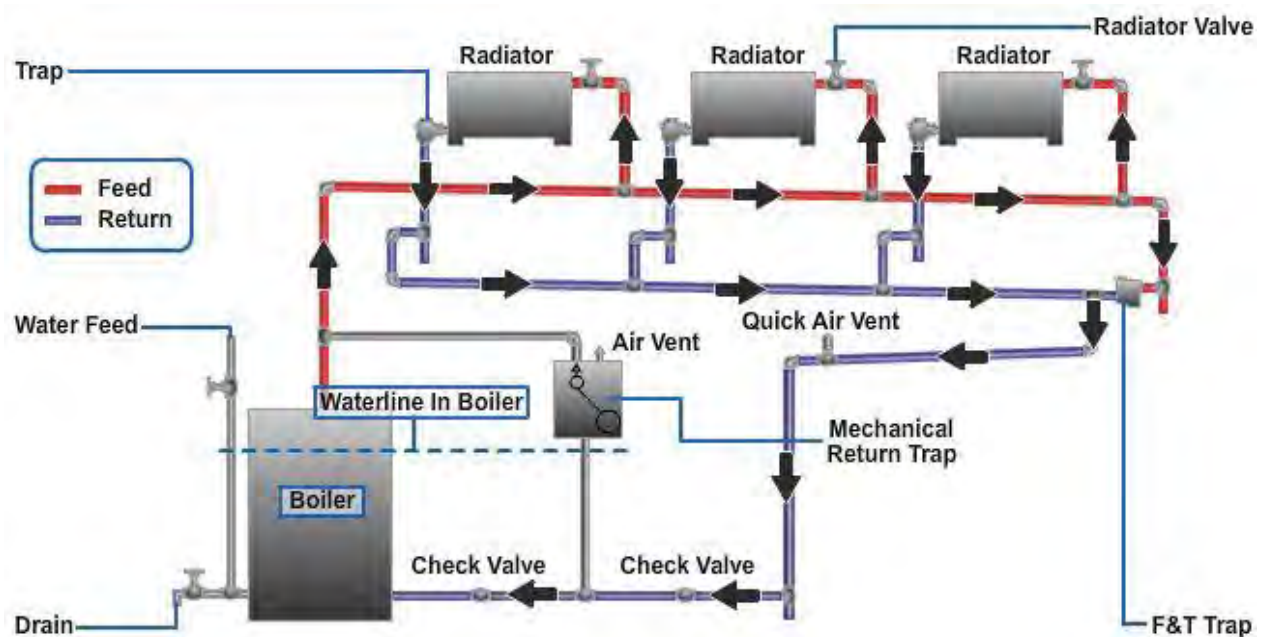

Figure 10-6 – Two-pipe vapor system with a return trap.

The return from the radiator has a thermostatic trap that permits the flow of condensate and air from the radiator. It also prevents steam from leaving the radiator. Because the return mains are at atmospheric pressure or less, a mechanical return trap is installed in the system to equalize the condensate return pressure with the boiler pressure. The mechanical return trap is primarily a double-valve float mechanism which permits equalization of the boiler pressure and the pressure within the return trap.

2.2.1 Installation

Vapor-steam systems with return traps are similar in design. However, two installations are seldom alike. Since the details differ with the type of heating equipment, the manufacturer's installation instructions should be followed.

However, the mechanical return trap should be installed on a vertical pipe in the return system that is adjacent to the boiler. The top of the trap should be level with or below the bottom of the dry return main. The bottom of the trap should be approximately 18 inches above the boiler waterline to provide a sufficient hydrostatic head to overcome friction in the return piping to the boiler.

2.2.2 Operation

The two-pipe vapor system with a return trap alternately fills and dumps. It returns condensate to the boiler by a mechanical alternating-return trap instead of by gravity. The alternating-return trap consists of a vessel with a float that, by linkage, controls two valves simultaneously so that one is closed when the other is open. One valve opens to the atmosphere; the other is connected to the steam header. The bottom of the vessel is connected to the wet return.

In operation, when the float is down, the valve connected to the steam header is closed and the other is open. As the condensate returns, it goes through the first check valve and rises into the return trap, which is normally located 18 inches above the boiler waterline. The float starts to rise when the water reaches a certain level in the trap, the air vent closes, and the steam valve opens. This action equalizes the trap and boiler pressures and permits the water to flow by gravity from the trap, move through the boiler check valve, and go into the boiler. The float then returns the trap to its normal vented condition, ready for the next flow of returning water.

2.2.3 Maintenance

The problems you are likely to encounter in maintaining the two-pipe vapor system with a return trap will differ with each system. Some of the more common troubles are discussed here. For specific instructions, you should refer to the manufacturer's manual or pamphlet pertinent to each piece of equipment.

When a radiator fails to heat, the air vent being plugged or the radiator being waterlogged because of a plugged or defective trap can cause the condition. In case there is a plugged air vent, all you need to do is clean it. When there is a waterlogged radiator, check the trap to determine if it is plugged; also check to see if the bellows is serviceable. If the trap is plugged, then cleaning it should solve your problem. However, if the trap is damaged, the damaged part, or the whole trap, must be replaced.

When the entire steam distribution system fails, the trouble can be caused by inoperative return traps or inoperative check valves. Clean and inspect the return traps and the check valves, and replace the defective parts or the whole unit if necessary.

2.3.0 Two-Pipe Vapor System With a Condensate Pump

The two-pipe vapor system with a condensate pump is similar to the two-pipe vapor system with the return trap, except that the condensate is returned to the boiler by a power-driven centrifugal pump instead of by a return trap (*Figure 10-7*).

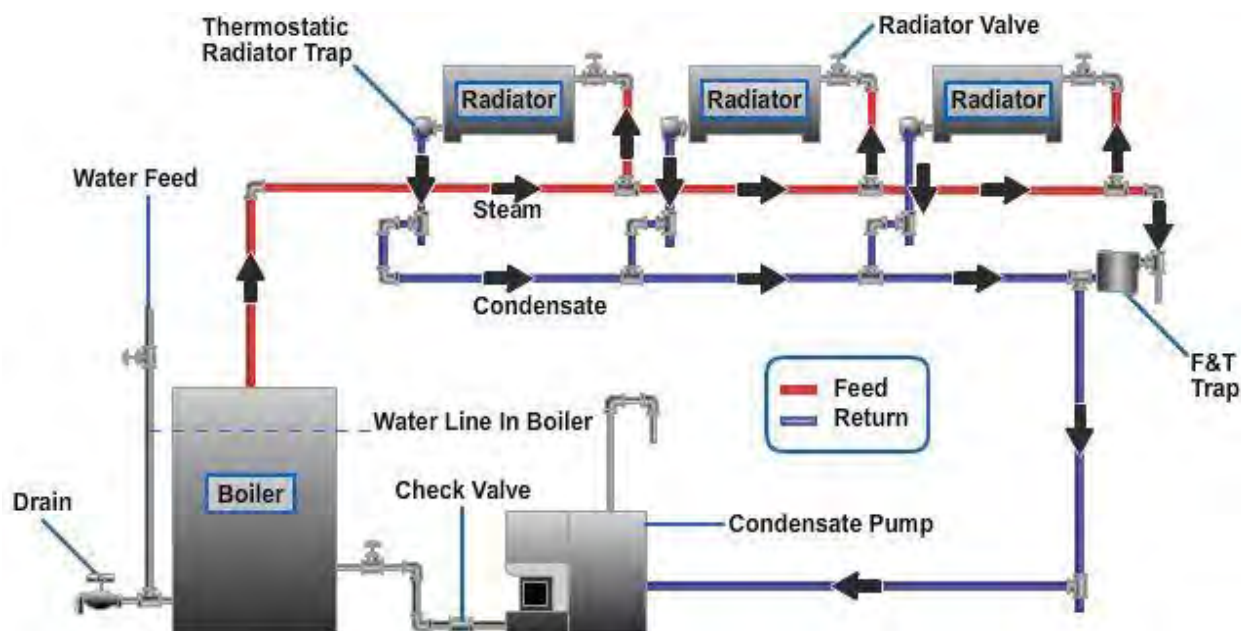

Figure 10-7 – Two-pipe vapor system with a condensate pump.

This system includes a separate main, a radiator feed at the top, and a return system with thermostatically trapped outlets located at the bottom of the radiators opposite to the feed end. The return main terminates at the receiver of the condensate pump, where all of the air in the system is discharged to a vent on the receiver. With the use of a condensate pump, all of the returns to the pump are kept dry and the radiators can be located below the boiler waterline. This is not possible with the steam distribution systems previously described. The radiators should be installed above the return main to permit gravity flow of the condensate from the radiator, and the return main should pitch downward to the pump receiver.

2.3.1 Installation

Two-pipe vapor systems with condensate pumps are basically alike in design. However, since two installations are seldom alike, it is necessary to install each system according to the mechanical blueprints furnished by the civil engineer and the instructions of the manufacturer of the equipment.

2.3.2 Operation

The two-pipe vapor steam distribution system can be operated at the pressure limit of the steam plant boiler, provided the condensate pump is designed for sufficient discharge head necessary to overcome discharge pipe friction loss, boiler pressure, and the hydrostatic head between the pump outlet and the waterline of the boiler. The ends of the steam mains are drained and vented into the dry return main through a combination float and thermostatic trap.

The two-pipe system with a condensate pump is adapted to relatively large installations and is probably the most practical and trouble-free system. Most vapor systems differ somewhat with each installation. For specific instructions for the correct operating

procedures, refer to the manufacturer's instructions for the specific type of equipment installed.

2.3.3 Maintenance

Most of the two-pipe vapor steam distribution systems differ from one system to another. Therefore, you will encounter different maintenance problems with each system. It is not feasible to try and cover all of the problems you might encounter with different systems of this type. However, the more common ones are discussed.

When you find that the individual radiator fails to heat, either an inoperative steam trap or a radiator that is not installed correctly can cause the trouble. Repairing or replacing the steam trap or correcting the improper installation of the radiator can eliminate these troubles.

When it is the whole distribution system that fails to heat, the causes include clogged or closed receiver vents, a flooded return line, the lack of pump capacity, or air binding the system. These troubles can be remedied by opening the vents, checking and adjusting the pump cut-in, replacing the pump, or repairing inoperative rerun traps.

One common trouble that occurs in this type of distribution system is the overflow of water from the receiver vent, usually caused by an inoperative pump. The pump may be causing the flooding because of its inadequate capacity or because it is unable to handle the volume of condensate required. This condition can be corrected by either repairing or replacing the pump.

Another cause of overflow of water from the receiver vents is an obstruction in the line between the condensate receiver and the boiler. The trouble can be remedied by eliminating the obstruction, regardless of whether it is a closed valve or a clogged line.

2.4.0 Two-Pipe Vapor System with a Vacuum Pump and a Condensate Return

The two-pipe vapor distribution system with a vacuum pump and a condensate return is similar to the two-pipe vapor system with a condensate pump (*Figure 10-8*). The piping in this system includes separate steam and return mains.

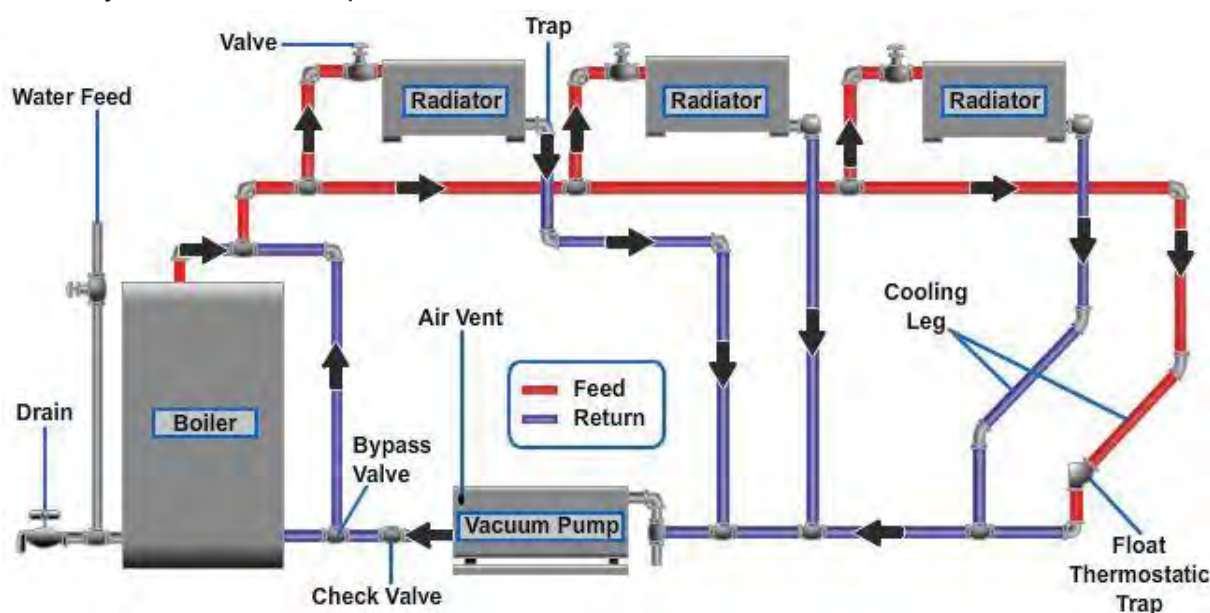

Figure 10-8 – Two-pipe vapor system with a vacuum pump.

2.4.1 Installation

Most vapor distribution systems with vacuum pumps and condensate returns are similar. However, two steam distribution installations are seldom alike in detail. When installing vapor-heating distribution systems, refer to the manufacturer's recommendations, civil engineer's mechanical drawings, and specifications for the proper installation procedures.

2.4.2 Operation

When this type of distribution system is operated, the steam is supplied at the top of the radiator and the air and condensate discharged through a thermostatic trap from the bottom of the opposite end of the boiler. All returns are dry and terminate at the vacuum pump. The vacuum pump is usually a motor-driven unit, although low-pressure steam turbines have been successfully used to a limited extent. The vacuum pump returns the condensate to the boiler and maintains the vacuum or sub-atmospheric pressure in the return system. The maintenance of a vacuum in the return system (3 to 10 inches of water) enables almost instantaneous filling of the heating units at low steam pressure (0 to 2 psi) since air removal is not dependent upon steam pressure.

The vacuum pump withdraws the air and water from the system, separates the air from the water, expels the air to the atmosphere, and pumps the water to the boiler, feedwater heater, or surge tank. Usually, the vacuum pump is supplied with a float switch as well as a vacuum switch, and it can be operated as a condensate pump unit. The float switch should be used only when the vacuum switch is defective, and then only until the defects can be repaired or corrected.

This system can be used in all types of buildings, and it is of particular advantage for the satisfactory operation of indirect radiation units, heating coils, and ventilating units, and for other units that requires close automatic control. Indirect radiation is a term applied to warm-air heating systems that receive their heat from steam supplied to their heat exchanger coils.

2.4.3 Maintenance

When considering the subject of maintenance on a two-pipe vapor distribution system having a vacuum pump, you will find that most of the troubles that have previously been discussed also apply to this system. In this distribution system, however, keeping air from leaking into the system is more of a problem than in the other distribution systems. Excessive air leakage often causes the pump to run all the time, or the leakage can cause the system to fail to heat altogether. To eliminate air leakage, you must find the point where air is leaking and repair it, so air cannot get into the system. Rusty spots and water seepage usually indicate the points at which air is leaking into the system.

Test your Knowledge (Select the Correct Response)

1. In a two-pipe vapor system with a return trap, the bottom of the trap should be how many inches above the boiler waterline?
 - A. 12
 - B. 14
 - C. 16
 - D. 18

3.0.0 STEAM DISTRIBUTION SYSTEM COMPONENTS

In previous sections of this chapter, you read about various components as you studied the various distribution systems. The components were only mentioned, however, and not explained in detail. Therefore, in this section, we are going to discuss these components, their purpose, operation, and maintenance.

3.1.0 Radiators

Steam radiators are normally classified into two categories. One is the fin-tube radiator, which consists of a metal tube that has metal fins attached on the outside to increase its total heating surface. It generally has a valve at one end and a trap at the other end. This radiator has been used more extensively in the past 15 years. It is readily adaptable to areas where floor space is limited, since the radiator is normally mounted on the walls. The second category is the cast-iron radiator, which is made in sections. A typical cast-iron radiator is shown in *Figure 10-9*. These radiators are similar to those used in hot-water heating systems. The cast-iron radiator is generally used in the one-pipe distribution system. In this system, there is only one distribution pipe connected to the radiator. This pipe delivers steam to the radiators, and it also returns water from the condensed steam to the boiler. For this reason, the radiators must be tilted slightly toward the distribution pipe.

The radiators in a two-pipe steam distribution system are connected to the boiler by means of a distribution pipe as well as by a condensate return pipe. Since the steam and condensate in the system flow in separate pipes, the pipes are smaller than those required for the same size radiator in a one-pipe system. The radiator outlet is usually equipped with a steam trap that prevents steam from leaving the radiator until it condenses into water.

3.2.0 Radiator Air Vents

There are two types of radiator air vents: automatic and manually operated. A typical automatic air vent is shown in *Figure 10-10*. Air vents are installed to remove air from the radiators because air keeps the radiator from heating properly.

The type of air vent shown consists of a hermetically sealed bellows, a valve disk and seal, and a vent body. The bellows contains a **volatile** liquid with a boiling point 10°F or lower than that of water. So, when this liquid is heated to a temperature 10°F below the steam and

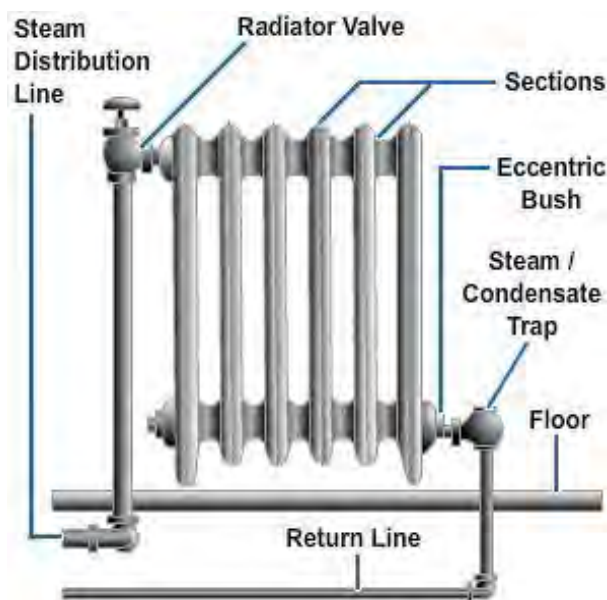

Figure 10-9 – Cast-iron radiator.

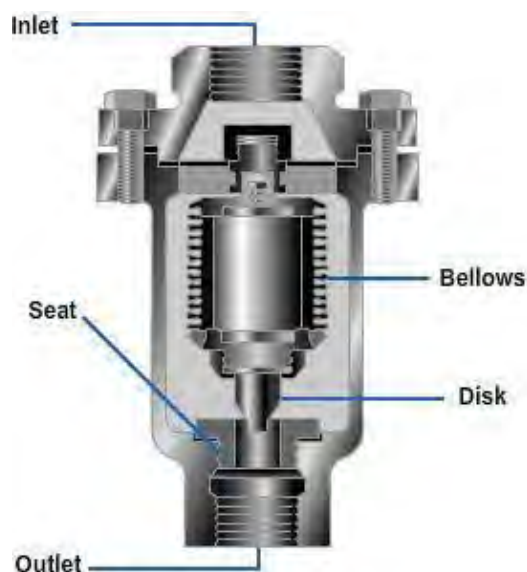

Figure 10-10 – Automatic air vent.

water temperature, the liquid volatilizes, expands, and closes the valve. When air surrounds the bellows, the air is cooler than the steam. This causes the bellows to contract, to open the valve, and to allow the air to escape. This cycle then starts over again.

The type that is operated manually is usually a small valve that has a slotted screw incorporated in the stem and a little spout on one side for the discharged air. These manual vents are normally installed in the same place in the distribution system as automatic vents.

3.3.0 Steam Traps

Steam traps are designed to retain the steam in a radiator or other using device until it changes into condensate. After the steam has turned into condensate, the trap releases the water so it can enter the return lines. However, it keeps the steam coming into the radiator from escaping. The trap performs an important function since the excessive accumulation of water prevents the proper heating of the radiator or other steam equipment. Also, steam that is permitted to blow through a defective trap results in heat loss.

3.3.1 Types of Traps

Traps are generally classified according to their operation. The most common types of traps are float, bucket thermostatic, float thermostatic, impulse, thermodynamic, throttling, and bimetallic element.

3.3.1.1 Float Trap

The float trap normally consists of a body, float, linkage, seat, and valve. A typical float trap is shown in *Figure 10-11*. As water enters the trap, the float rises, opens the valve, and allows the accumulation of water to flow into the return lines that take it to the boiler. When the water has run out, the float falls, closes the valve, and traps the steam.

The maintenance to be done on a float trap is simple. One of the most common difficulties is that the float gets water in it and does not rise. In this case, the float must be replaced. The valve sometimes gets plugged or worn and has to be cleaned or replaced.

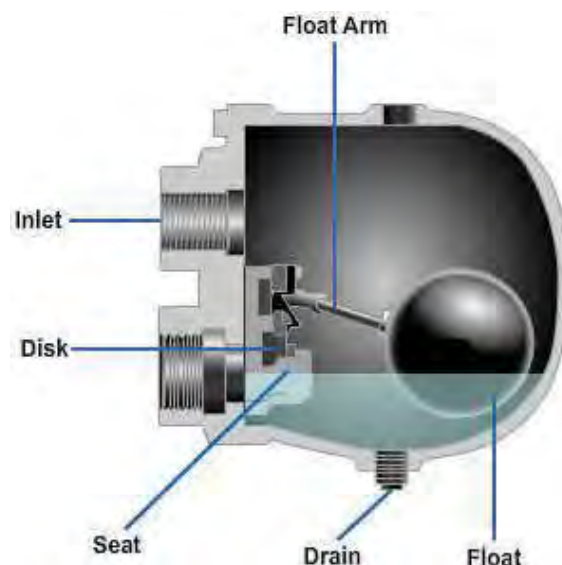

Figure 10-11 – Float trap.

3.3.1.2 Ball-Float Trap

In a ball-float trap, the valve of the trap is connected to the float so the valve opens when the float rises. When the trap is in operation, the steam and water that may be mixed with it flow into the float chamber. As the water level rises, the float is lifted, thereby lifting the valve plug and opening the valve.

The condensate drains out and the float moves down to a lower position, then closes the valve. The condensate that passes out of the trap is returned to the feed system.

3.3.1.3 Bucket Trap

There are two types of bucket traps: the upright and the inverted. An example of the inverted bucket trap is shown in *Figure 10-12*.

During operation of the upright bucket trap, the steam and water both enter the trap body. As the water enters, it causes the bucket to float and the valve to close. The water continues to rise; it overflows into the bucket, which sinks. When the bucket sinks, the trap valve is opened and the steam pressure forces the water out. When all of the water is expelled from the bucket, the bucket again floats, the valve closes, and the cycle starts again.

During the operation of the inverted bucket trap, the steam and water both enter under the bucket. The steam makes the bucket buoyant, causes it to rise, and closes the valve. When the steam condenses, the bucket drops, opens the valve, and the steam blows the water out of the trap.

Maintenance on bucket traps consists mainly of cleaning and inspecting them periodically. If the trap begins to leak steam, replace the valve disk and seat. However, if the bucket fails to open the valve, the trap usually becomes waterlogged. When a valve disk or seat becomes damaged, the trap allows steam to leak through. The condensate return line becomes excessively hot when the trap is leaking steam. Bucket traps contain some water at all times. Therefore, they must be drained when the system is to be off during freezing weather.

3.3.1.4 Thermostatic Trap

The thermostatic trap is often used on radiators and is commonly known as a radiator trap. It has a bellows that contains volatile fluid that expands and vaporizes when heated. Pressure builds up inside the bellows and causes it to lengthen and close the valve. A typical thermostatic trap is shown in *Figure 10-13*.

When water collects around and cools the bellows, the bellows contracts. This action opens the valve and permits water to escape. As the water goes out, the steam that enters contacts the bellows and

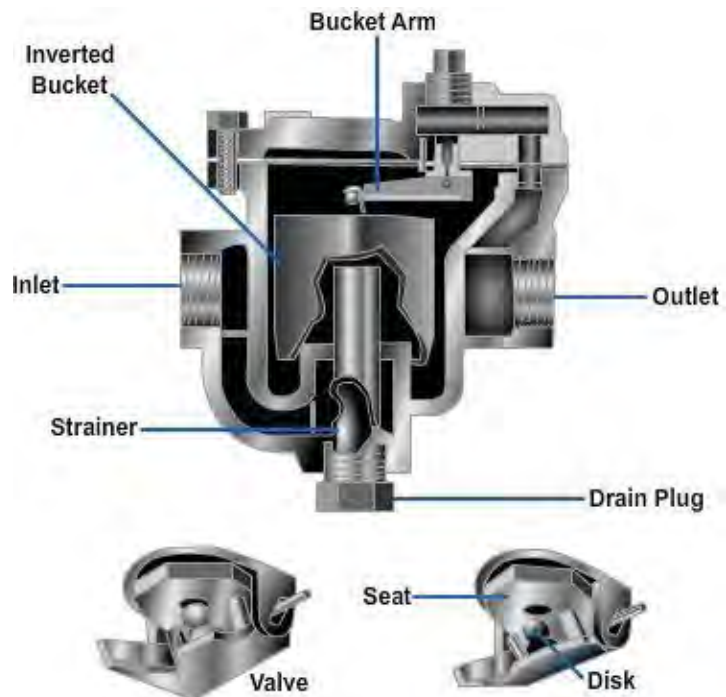

Figure 10-12 – Inverted bucket trap.

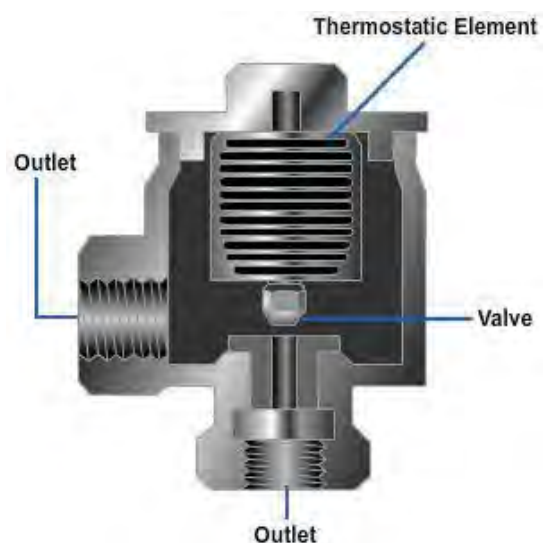

Figure 10-13 – Thermostatic trap.

causes it to expand, closing the valve and preventing the steam from escaping.

The most common trouble with the thermostatic trap is that the bellows develops holes, fails to work, and has to be replaced. The bellows and lower valve seat can be removed for repair without disconnecting any of the piping.

3.3.1.5 Float Thermostatic Trap

The float thermostatic trap operates on the principle of the float trap and the thermostatic trap. Practically the same maintenance is required. A typical example of the float thermostatic trap is shown in *Figure 10-14*. The thermostatic bellows acts as an air eliminator.

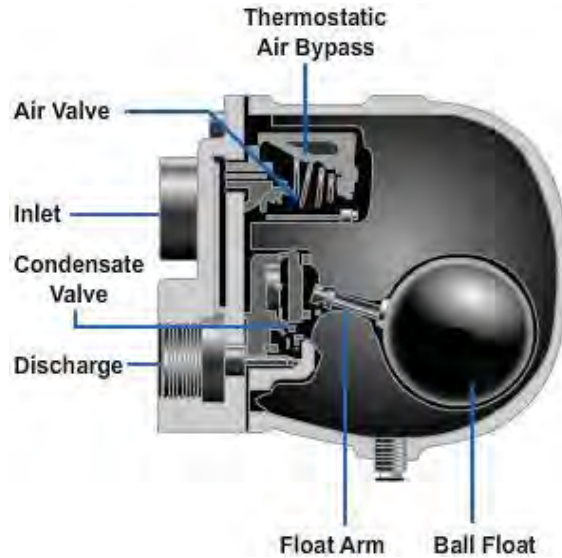

Figure 10-14 — Float thermostatic trap.

3.3.1.6 Impulse Trap

The operation of the impulse trap is based on the principle that a portion of hot water, under pressure, flashes into steam when its pressure is reduced (*Figure 10-15*). The trap is operated by a moving valve impelled by changes of pressure in a control chamber. The valve has tiny orifices drilled through its center that allow the continuous bypassing of condensate from the inlet of the trap to the control chamber. This bypassing reduces the chamber pressure below the inlet pressure so the valve opens and allows free discharge of the condensate. The temperature of the remaining condensate rises and flashes back to steam. The flow through the valve orifice is choked and pressure builds up in the control chamber, closing the valve.

About 5 percent of the rated capacity of the trap flows through the valve orifice. The pressure on the discharge side of the trap should not be over 25 percent of the inlet pressure if the trap is to function properly. Very little maintenance, except some periodic cleaning, is required for the impulse trap. The trap may be disassembled for cleaning or repairing without disturbing any of the piping.

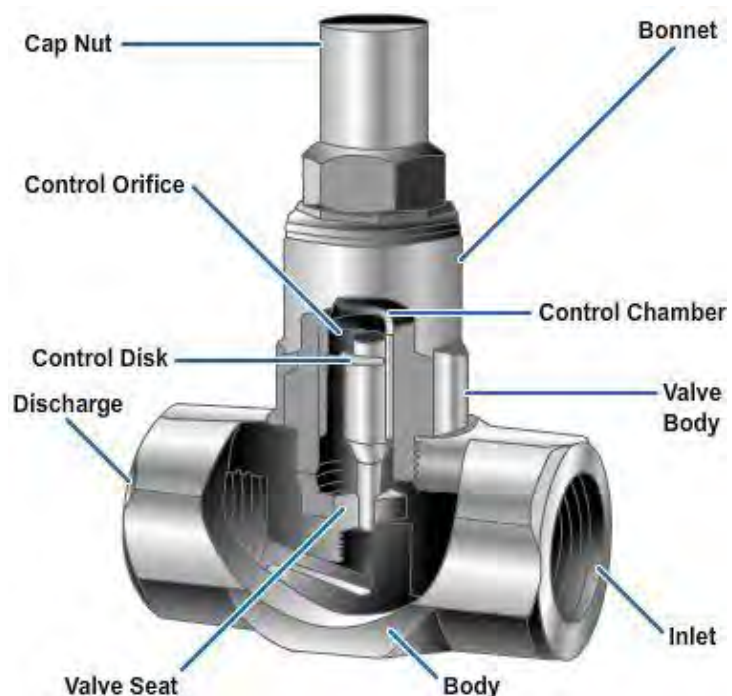

Figure 10-15 — Impulse trap.

3.3.1.7 Thermodynamic Trap

A typical thermodynamic trap is shown in *Figure 10-16*. It contains only one moving part—a disk. This disk is operated by changes in steam pressure. Pressure under the disk raises it to allow the condensate to be discharged. Droplets of condensate form on top of the disk. Then steam enters at high velocity and creates a low pressure under the disk; the droplets of water above the disk then flash into steam and create a high pressure above the disk. (Water expands to as much as 1,728 times its volume when it changes to steam.) The high pressure against the top of the disk overcomes the lower pressure of the incoming steam, so the trap closes. As more condensate collects in the trap, the steam above the disk condenses and relieves the high pressure and the cycle is repeated.

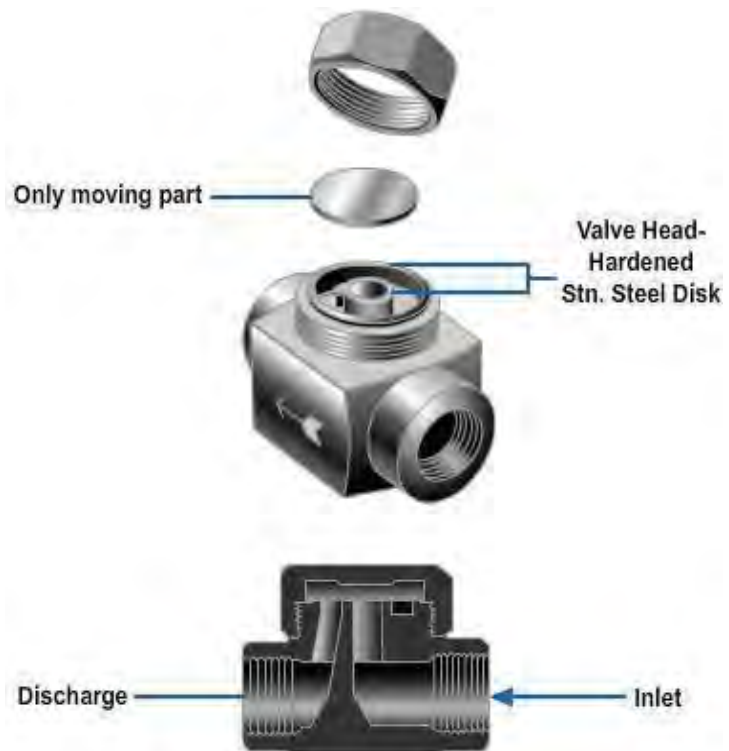

Figure 10-16 – Thermodynamic steam trap.

The most common trouble is that the trap becomes plugged and has to be disassembled and cleaned. The thermodynamic trap can be cleaned or repaired without disturbing any of the piping. Very little other maintenance is required for this trap because of its simple construction. Also, the trap is usually constructed of stainless steel.

3.3.1.8 Throttling Trap

The operation of the throttling trap is based on the principle that the flow of water through an orifice decreases as its temperature approaches that of the steam used (*Figure 10-17*). The rate of flow of the condensate may be adjusted by raising or lowering a stem (needle valve) that fits into a tapered seat. This throttling trap has no moving parts.

Condensate that is slightly cooler



Figure 10-17 – Throttling trap.

than steam enters the trap, travels up through a baffle arrangement, and is discharged through an orifice. If the condensate discharge rate is higher than the inlet rate, the water (condensate) level in the chamber drops. This allows steam to enter the baffle passage and heat the condensate. The amount of water flashing into steam increases, so the volume of steam-water mixture handled by the orifice increases and thereby reduces the capacity of the orifice. The reduced flow through the orifice permits the level of condensate in the chamber to rise until the heater water in the baffle passage has been completely discharged and replaced with water that is slightly cooler. Then the cycle is repeated. Air is vented from this trap through the same passage as the condensate. The throttling trap can be replaced without disturbing any of the piping.

3.3.1.9 Bimetallic-Element Trap

The bimetallic-element trap contains bimetallic elements that bend when heated (*Figure 10-18*). The metals in the bimetallic strip generally are Emvar and copper. The copper expands rapidly when heated, but Emvar expands very little. Therefore, the bimetallic strip bends when it is heated. This trap may be used for higher or lower steam pressure by increasing or decreasing the number of bimetallic leaves in the trap.

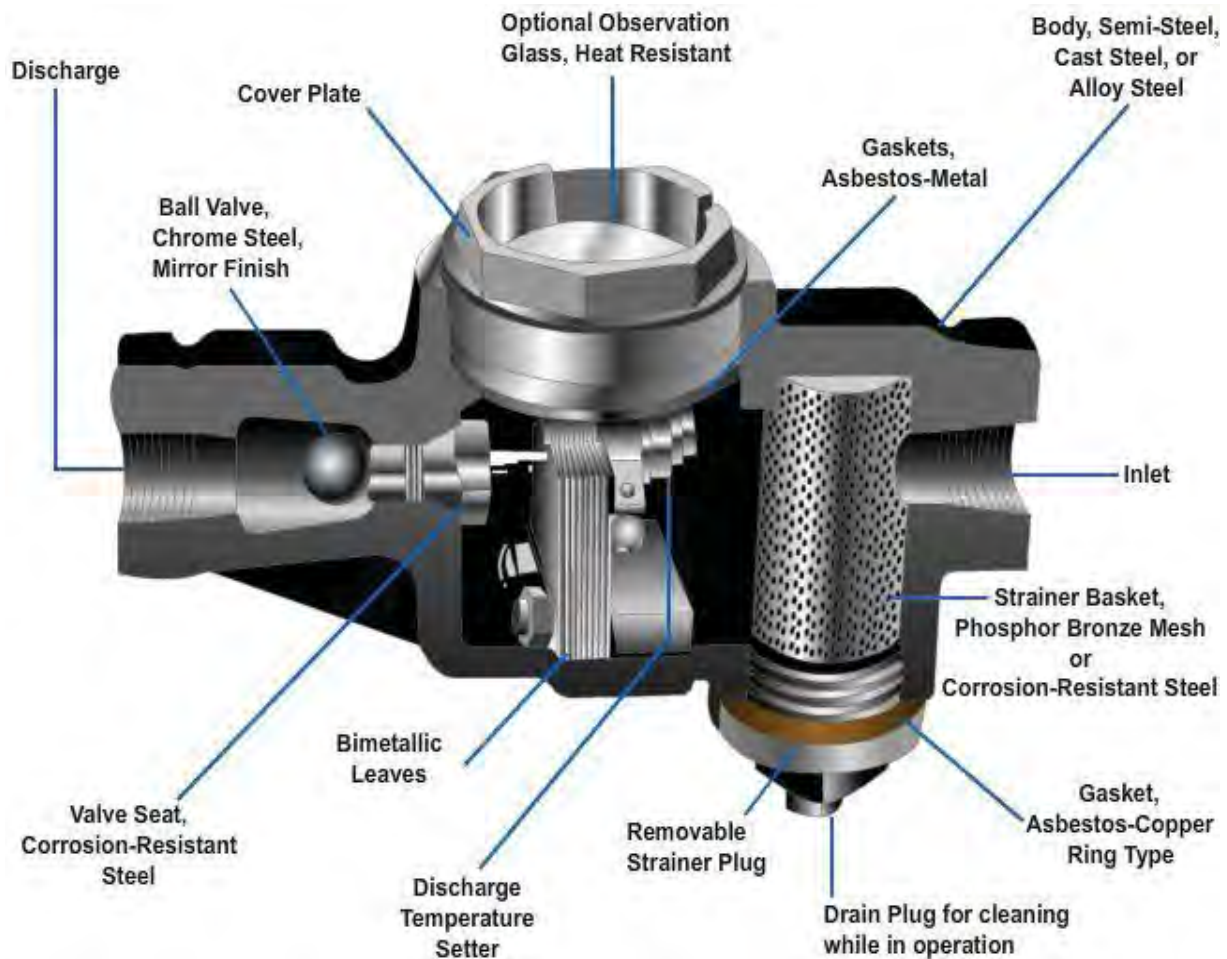

Figure 10-18-Bimetallic-element steam trap.

This trap works basically the same as the thermostatic trap. When steam enters the trap, the element is heated and bends, thus closing the valve. As steam condenses, the elements cool and straighten out to allow the valve to open and let the condensate escape. The bimetallic trap can be repaired without disturbing any of the piping.

3.3.2 Pointers on Operating Procedures

To help ensure trouble-free service of steam traps, follow the proper operating procedures carefully. Some important factors involving operating procedures are furnished below.

- Steam traps should be operated within the capacity rating and pressure differentials recommended by the manufacturer. Use traps for the correct pressure and temperature. If operating pressures change, it may be necessary to change trap sizes, or internal parts, to fit the new pressure conditions.
- Traps should be insulated where heat must be conserved. Some types of traps which depend on the cooling effect of the condensate for operation should be left bare. Check the manufacturer's instructions regarding insulation.
- Where continuity of service is a requirement, a three-valve bypass is usually provided to permit drainage while the trap is being overhauled. Bypasses are also used to speed up the discharge of condensate and air when you are starting a system. In normal operation, however, the bypass valve should be kept closed to prevent steam from being wasted.
- Check valves, located in the discharge line, are important in parallel installations to prevent the discharge of one trap from backing up into that of another. Also, when condensate from the trap must discharge to a higher elevation, a check valve prevents backflow of condensate.
- Inverted bucket traps must be primed for operation by providing a condensate seal in the bottom of the trap. Prime the trap before starting operation by removing the test plug on top of the trap and filling the trap with water. If no test plug is available, the trap can be primed by closing the discharge valve and opening the steam supply valve slowly until the steam is condensed and the trap is filled with condensate.
- Blow down steam traps periodically to rid them of dirt and sediment. Blow down and clean strainers as required.
- When overhauling traps, do not remove thermostatic elements while hot. This practice may result in expansion beyond the stroke range of the bellows or diaphragm.
- Periodically, open the air vents of float traps not provided with thermostatic air vents to vent out accumulated air.

3.3.3 Steam Trap Tests

Methods for testing traps without breaking the installation are stated below.

3.3.3.1 Test Valve Method

Close the discharge valve and open the test valve. Observe discharge characteristics. Intermittent discharge, dribble, or semi-continuous discharge indicates correct operation. A continuous steam blow indicates loss of prime, defective valve operation, or foreign matter embedded in the valve seat. A continuous condensate flow may indicate that the trap is too small, the amount of condensate is abnormally high, or a pressure differential that is too low.

3.3.3.2 Glove Test Method

Grab inlet and outlet pipes simultaneously, using a canvas glove on each hand for protection. A slight temperature difference indicates that no condensate is passing.

3.3.3.3 Pyrometer Test Method

This method is more accurate than the previous one, as it uses a surface contact **pyrometer** to check inlet and outlet temperatures. File a clean spot on both pipes before taking readings.

3.3.3.4 Pyrometric Crayon Test Method

Temperature-indicating crayons can be used when no pyrometer is available. Select crayons of proper temperature ratings and mark the required pipe spots. When the crayon marks melt, the temperature of the test spots corresponds to those of the crayon ratings.

3.3.3.5 Ear Test Method

Hold one end of a metal rod to the trap body and place the other end in your ear, or use an engineer's stethoscope. If the trap is operating properly, you will hear the regular opening and closing of the valve. If operation is defective, you will hear considerable rattling or the continuous flow of steam.

3.3.3.6 Protection Against Freezing

Protect traps from freezing in cold weather. If the steam is shut off during freezing weather, drain the traps and piping of all condensate. Make certain insulation is in good condition. The inverted bucket is especially prone to freezing because, in normal operation, it is half filled with water.

3.4.0 Water Tanks

It is virtually impossible to operate a boiler plant and heating system in perfect balance. The demand for water by the boiler may exceed the rate at which water is being returned from the heating system, or the water may be returning at a rate that is greater than the requirements of the boiler. One or more tanks can be installed to compensate for uneven flows and for differences between the demand and supply of water. These vessels are called surge tanks (*Figure 10-19*).

Sudden reductions in pressure may lead to violent steam formation. Flash tanks help eliminate disturbances in the



Figure 10-19 – Surge tank.

pipng system caused by this process. These tanks are usually small and are located near the traps where the pressure release occurs.

When the steam condenses, the steam trap, usually a float thermostatic type, allows the condensate to drain into the condensate return line. A strainer is installed just ahead of the trap to keep foreign matter out of the trap.

3.5.0 Water Heaters

Steam-operated water heaters are used to supply hot water for laundries, dining halls, latrines, and other facilities. There are two general types of these heaters: storage and instantaneous.

3.5.1 Storage Type

The storage type of water heater is used to provide potable (drinking) water. The steam-operated storage type of water heater consists of a steel tank that contains a steam coil like that shown in *Figure 10-20*.

The hot-water tank is connected to the base water supply system and remains full of water at all times.

The steam is circulated through the heating coil or "bundle," as it is sometimes called. The heat from the steam is transferred through the walls of the coil to the water in the tank. Because of the difference in weight between hot and cold water, the hot water rises and the cold water goes to the bottom of the tank where the steam coil is located.

Here the water is heated and begins to circulate. Eventually, all of the water in the tank becomes heated. When hot water is

drawn, more cold water enters the tank and this heating process repeats itself. This action maintains a full tank of hot water for use whenever hot water is needed.

According to safety regulations, the hot water should not exceed 180°F. The storage type of water heater may be constructed to be installed in either the horizontal or the vertical position.

Tappings are usually provided in the tank for a thermometer—a thermostatic element for a temperature-regulating valve (which will be discussed later in this section) and a safety valve. The tube coil should be inspected annually to make sure steam is not leaking into the water. The chemicals that are sometimes used in the steam may make the people who use the water sick if they drink it.



Figure 10-20—Storage-type water heater.

3.5.2 Instantaneous Type

Instantaneous heaters are used primarily as boiler feedwater heaters; however, they are sometimes used to provide potable (drinking) water at some installations. The operation of the instantaneous-type heater is basically the same as the storage-type heater; their construction, however, is quite different. The diameter of the instantaneous heater is small in comparison to the storage-type heater. The outer shell of the instantaneous heater is small in comparison to the storage-type heater. The outer shell of the instantaneous heater barely covers the tube coil, as you can see in *Figure 10-21*. In some makes, the water is circulated through the coil, and the steam is released in the shell and surrounds the coil. A temperature-regulating valve controls the water temperature for both types of heaters.



Figure 10-21 - Instantaneous-type water heater.

3.6.0 Temperature Regulators

The temperature regulator is used to regulate the quantity of steam necessary to maintain the hot water at the desired temperature. The unit consists of a temperature bulb, copper line, diaphragm, spring and temperature adjustment, and steam valve. A typical temperature-regulating valve is shown in *Figure 10-22*.

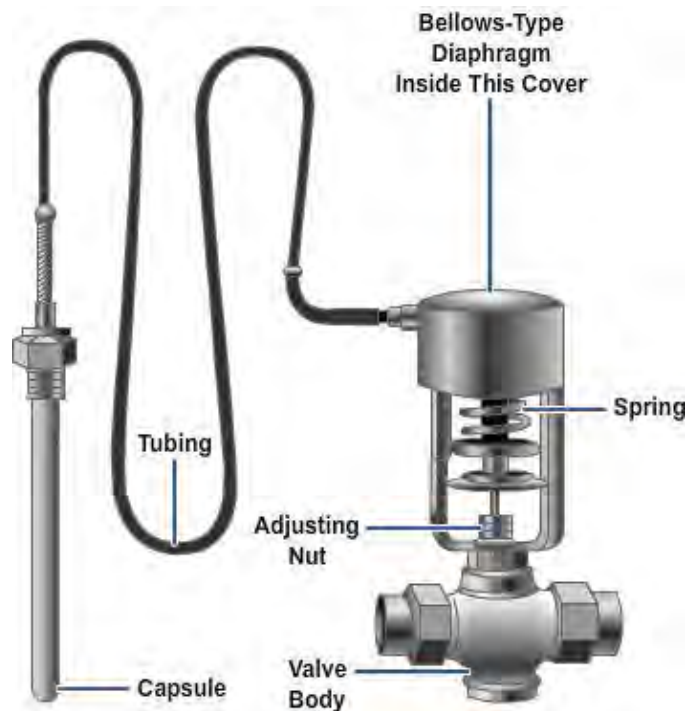

Figure 10-22 - Temperature-regulating valve.

The bulb and copper tube are called the capsule and capillary tube. They contain a gas that expands or contracts with a change in temperature. The capillary tube is connected to the top of the temperature regulator which contains a diaphragm (bellows). The diaphragm (bellows) is connected to the valve stem. A spring holds the valve open at low temperatures. When the temperature rises in the water tank, the gas in the temperature bulb expands and forces the diaphragm down, closing the steam valve. Adjusting the tension of the spring can control the water temperature. A steam trap in the steam-heating system returns the condensed steam to the condensate tank.

The hot-water tank accessories consist of a temperature gauge that has a range of 40°F to 210°F and a safety valve or pressure relief valve. The relief valve is set at a pressure that is 10 pounds higher than the operating pressure, and both the setting and the valve must comply with current American Society of Mechanical Engineers (ASME) code specifications.

3.7.0 Condensate Pump Return

Condensate return pumps move the water that has condensed from the steam in radiators, heating coils, convectors, and unit heaters to circulate back to the boiler. One type of condensation return pump is shown in *Figure 10-23*. Units of this type normally consist of a receiver or condensate tank and pump independently controlled by float switches. A check valve and a vent on the receiver allow the receiver to fill and empty as the need arises.

Condensate return pumps are maintained as prescribed by the manufacturer of the unit. Usually, the motor should be oiled, the check valves and vents cleaned, the float switches adjusted, the pump repacked, and the tank cleaned at least once each year.

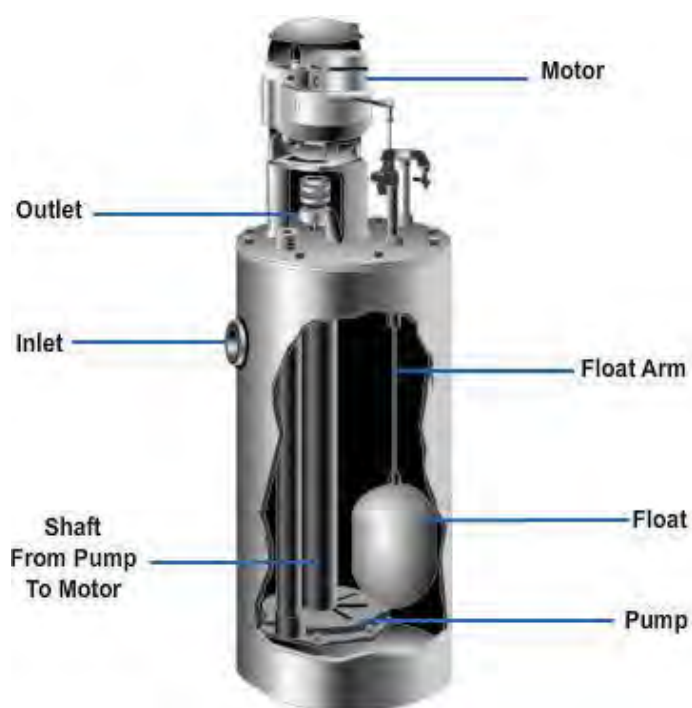

Figure 10-23 – Condensate return pump.

3.8.0 Expansion Joints

Expansion joints and expansion loops in long heating lines are convenient devices for handling the pipe elongation caused by expansion. The five major types of expansion joints are as follows: slip joint, bellows joint, swing joint, expansion loop, and ball joint.

The slip joint is shown in *Figure 10-24*. The female part of the joint is placed over the male part and the joint is held tight by the packing that permits expansion. The kind of packing used determines the temperature to which the joint can be subjected.

The bellows joint has a metal bellows that flexes as expansion occurs (*Figure 10-25*). The joint consists of a thin-walled corrugated copper stainless steel tube clamped between flanges. Rings help to keep the corrugations under relatively high pressure. The steam pipe and joint should be supported and guided to keep misalignment to a minimum.

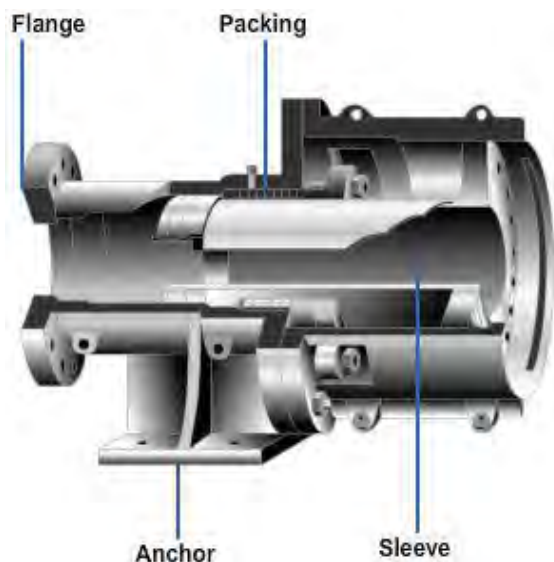

Figure 10-24— Slip-type expansion joint.

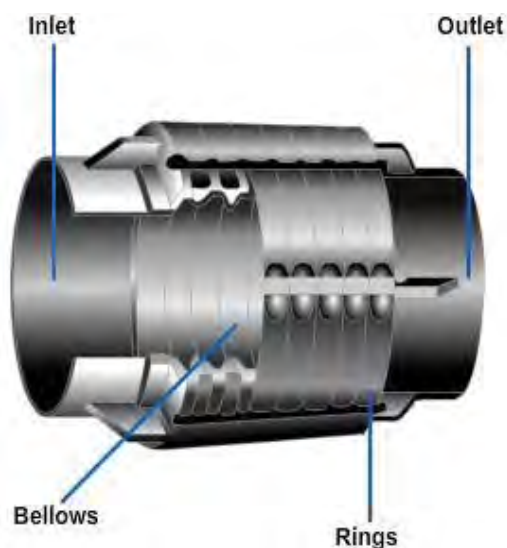

Figure 10-25– Bellows-type expansion joint.

The swing, or swivel, joint is most often used to allow expansion to occur naturally in a system that has threaded joints. When it is used with welded elbows, the swing joint introduces torsional strains in the elbows and in the swing piece.

The expansion loop absorbs expansion through the formation of U- or Z-loops in the pipeline.

The ball joint is often used instead of the expansion loop because it requires less space and material. A ball joint consists of four basic parts. The joint has a casing or body to hold the gaskets and a ball. The ball is a hollow fitting shaped externally like a ball at one end (inside the casing) and is threaded, flanged, or adapted for welding to the pipe at the other end. There are two gaskets that hold the ball and provide the seat. There is also a retaining nut or flange that holds the ball and gaskets in the casing. The end of the two pipes being coupled is connected to the joint casing; the end of the other pipe is connected to the ball. In operation, the ball joint allows the movement of the pipe with 30° to 40° of flexibility, plus a rotating or swivel motion of 360°.

The slip-type joint must be kept properly aligned, adequately packed, within the proper limit of travel, and thoroughly cleaned and lubricated. You should adjust or replace the packing, as required, to prevent leaks and assure a free-working joint. It is necessary to lubricate every 6 months with the proper grease for this type of joint and the service conditions. Once a year, you should check the flange-to-flange distance of the slip joints. You should check the flanges first when they are cold and next when they are hot. Measuring makes sure that the travel is within the limits shown in the manufacturer's data. A change in slip travel usually indicates a shift in anchorage of a pipe guide, so you must locate and correct the difficulty. You should also inspect annually for signs of erosion, corrosion, wear, deposits, and binding. Then you should repair or replace the defective parts, as required.

Check the bellows-type joint annually for misalignment, metal fatigue, corrosion, and erosion. You should note the amount of travel between cold and hot conditions. If the joint fails, you should replace the bellows section of the joint.

Expansion loops require little specific maintenance except inspection for alignment and leaks.

The ball joint must be kept adequately packed. You should adjust or replace the gaskets, as required, to correct leaks and obtain a free-working joint. Always refer to the manufacturer's instructions for doing maintenance work.

The swing joint requires the same typical maintenance for pipe fittings.

Summary

As a UT, you will be involved with the installation, operation, and maintenance of various types of steam distribution systems such as exterior and interior steam distribution systems. You must understand the purpose and equipment associated with underground and aboveground systems.

You will also be involved in the installation, operation, and maintenance of several interior steam distribution systems such as gravity, one-pipe, air-vent, two-pipe vapor system with a return trap, two-pipe vapor system with a condensate pump, and two-pipe vapor system with a vacuum pump and condensate return. As a UT you will be responsible for the upkeep and maintenance of several steam distribution components such as radiators, radiator air vents, steam traps, water tanks, water heaters, temperature regulators, condensate pump returns, and expansion joints. The information presented in this chapter will help you perform your duties with confidence and accuracy.

Trade Terms Introduced in this Chapter

Utilidor	An aboveground, insulated network of pipes and cables, used to convey water and electricity in communities situated in areas of permafrost.
Volatile	Evaporating rapidly; passing off readily in the form of vapor.
Pyrometer	An apparatus for measuring high temperatures that uses the radiation emitted by a hot body as a basis for measurement.

Additional Resources and References

This chapter is intended to present thorough resources for task training. The following reference works are suggested for further study. This is optional material for continued education rather than for task training.

Basic Machines, NAVEDTRA 12199, Naval Education and Training Professional Development and Technology Center, Pensacola, FL, 1994.

OSHA Regulations (Standards -29 CFR)

Naval Construction Force Manual, NAVFAC P-315, Naval Facilities Engineering Command, Washington, D.C., 1985.

Facilities Planning Guide, NAVFAC P-437, Volumes 1 and 2, Naval Facilities Engineering Command, Alexandria, VA, 1982.

Fluid Power, NAVEDTRA 12964, Naval Education and Training Professional Development and Technology Center, Pensacola, FL, 1994.

National Standard Plumbing Code-Illustrated, National Association of Plumbing-Heating-Cooling Contractors, Washington, DC, 2006.

Safety and Health Requirements Manual, EM-385-1-1, Department of the Army, U.S. Army Corps of Engineers, Washington, DC, 1992.

International Plumbing Code 2009, International Code Council

International Mechanical Code 2009, International Code Council

R. Dodge Woodson, *Plumber's Quick-Reference Manual Tables, Charts, and Calculations*, 1st edition, McGraw-Hill, NY, 1996.

Water Testing Kit, Chemical Agent: M272, Technical Operations Manual, TM 3- 6665-319-10, Department of the Army, Washington, DC, 1983

Boiler Care Handbook, Cleaver-Brooks Division of Aqua-Chem. Inc., Milwaukee, WI, 1985.

COMFIRSTNCDINST 3500.1, Operational Risk Management (ORM).

COMFIRSTNCDINST 5100.2, Naval Construction Force Occupational Safety and Health Program.

UFC 3-430-07, Inspection and Certification of Boilers and Unfired Pressure Vessels.

Maintenance of Steam, Hot Water and Compressed Air Distribution Systems, NAVFAC MO - 209, Naval Facilities Engineering Command, Alexandria, VA, 1989.